

# Barrier systems

Access control system for your entrance





# WE DELIVER THE QUALITY – YOU ENJOY THE CONVENIENCE!

With reliable products from SOMMER, you can be assured of durability for years to come. This is not only because of their high quality and easy operation, but also because they are meticulously crafted and certified,

which allows you to find the perfect barriers for your entrance.

The operating forces are certified according to EN 12445 and EN 12453.

## YOUR SAFETY WILL ALWAYS BE WHAT DRIVES US

Safety and accident protection are SOMMER's highest priority. Our barriers are equipped with dependable technology that complies with applicable standards.

The automatic obstacle recognition system provides protection by automatically opening when an obstacle is encountered (reversion). The Dynamic Power System automatically reads in the required force and adapts it to changing outside conditions.

In some models, a warning light is integrated in the aluminium housing, meaning you benefit from an attractive design as well as optimum safety.

Set up, plug in, done! The installation couldn't be easier. The boom can be shortened on-site to fit your requirements in just a few work steps. And with SOMMER, you can order exactly what you need: Both left- and right-closing models can be manufactured in our production facilities.

This means no adaptations are necessary during installation.

You also profit from the light aluminium material during installation. Easy handling makes for short assembly times. With maximum stiffness, for instance the ASB-6010A is extremely sturdy and has a very long service life. Even the toughest weather conditions do not harm it. The countless connection options will also win you over.

BARRIERS:  
WE HAVE **THE**  
**RIGHT** ACCESS  
CONTROL  
SYSTEM FOR  
YOUR ENTRANCE

4

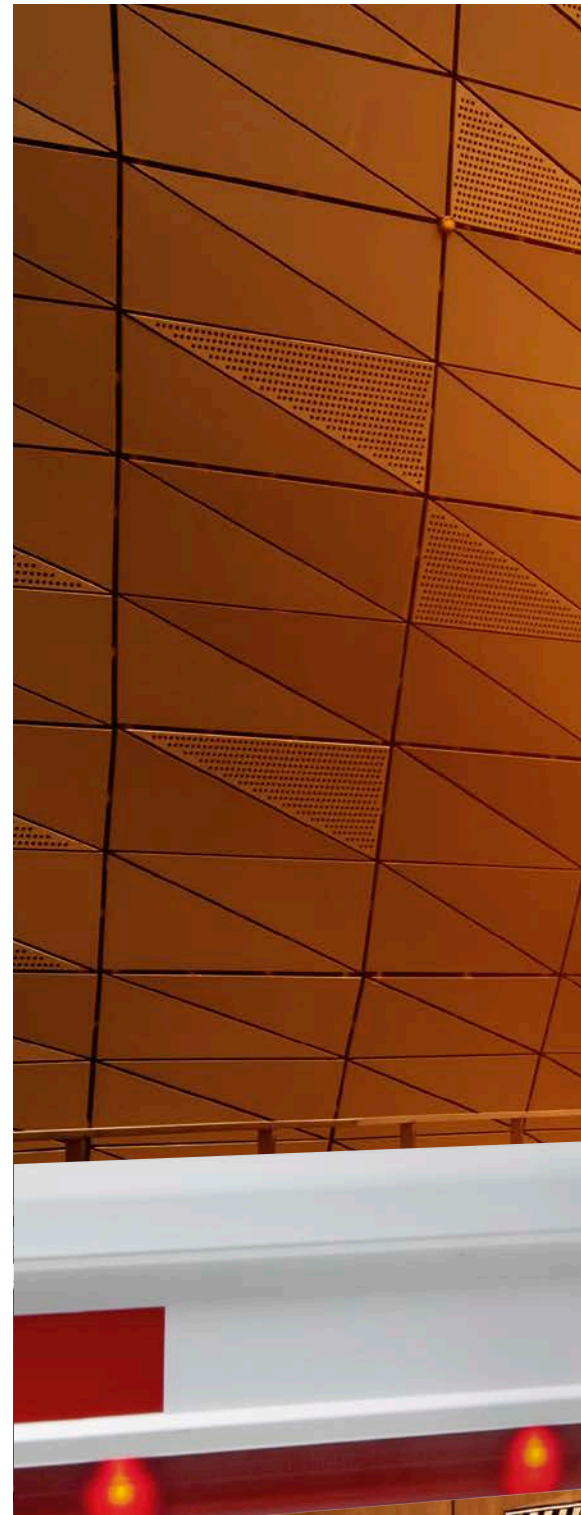

**[ WHETHER THE PROPERTY IS PRIVATE OR COMMERCIAL, ]**  
BARRIERS ARE ALWAYS THE RIGHT CHOICE

If public parking spaces are to be secured from unauthorised entry, SOMMER has an attractive complete solution: Our barriers are extremely reliable and need very little maintenance.





**SOMMER**  
www.sommer.eu

# NO CONVERSION WORK DURING INSTALLATION

Just order exactly what you need. Both left- and right-closing barriers are available. This means no adaptations are necessary during installation.

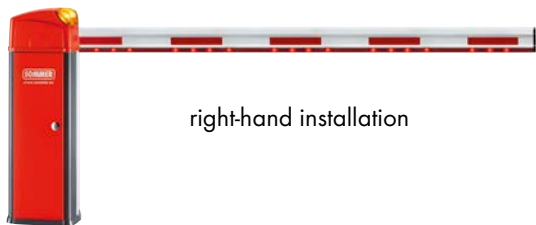

right-hand installation



left-hand installation

6

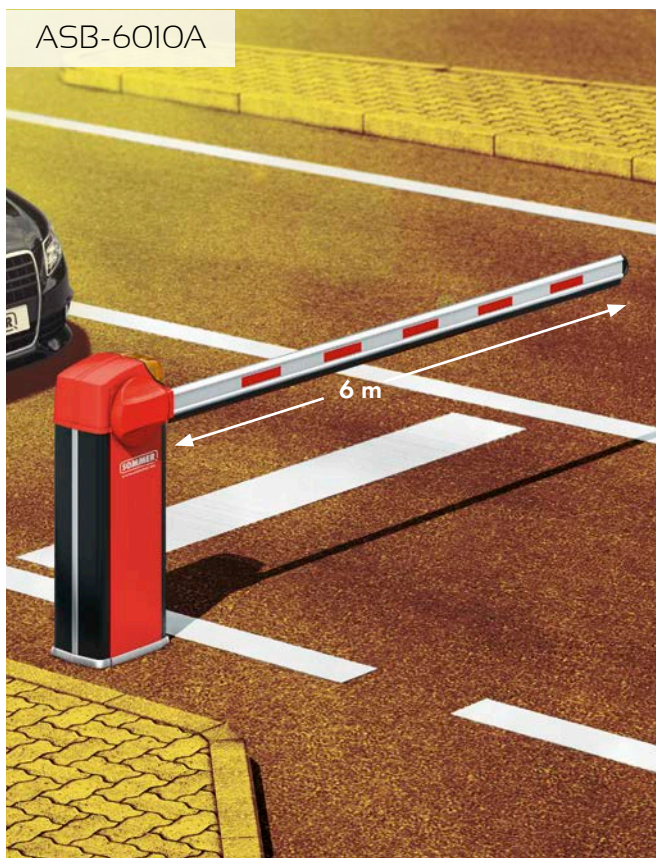

ASB-6010A

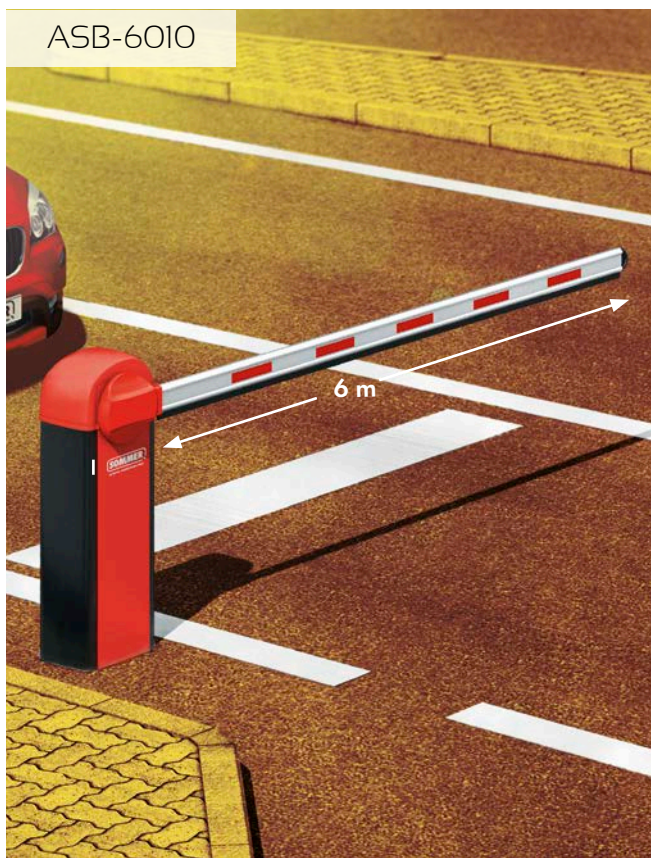

ASB-6010

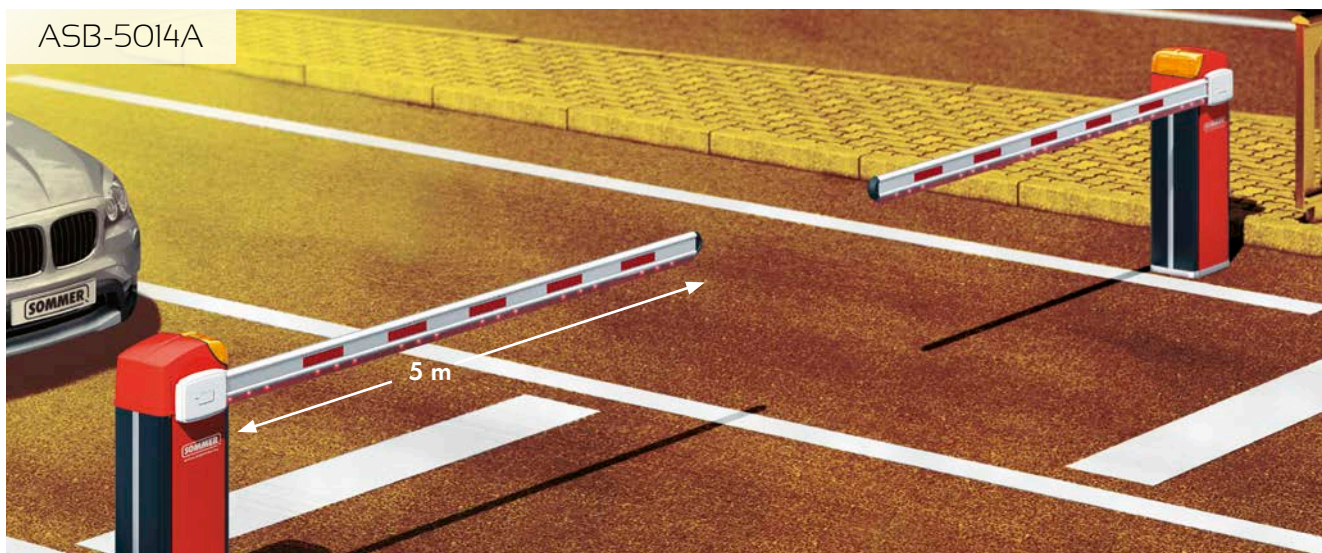

ASB-5014A

# ASB-5014A

The aluminium barrier with 5 m LED arm



left-hand installation:  
# 7653V001

right-hand installation:  
# 7654V001

- simple and fast mounting due to the "Plug & Go" principle: install, plug-in, ready!
- barrier arm can be easily shortened on site
- easily operated via integrated SOMMER radio receiver (FM 868.8 MHz)<sup>1)</sup>
- the automatic obstruction detection ensures optimum protection: when it contacts an obstacle the barrier opens automatically and ensures that no vehicle is clamped
- the operating force of our barriers is certified according to EN 12445 and EN 12453
- the barrier can be manually opened and closed in any position by means of the emergency crank (e. g. in the event of a power failure)
- also available at SOMMER are support posts<sup>2)</sup>
- pluggable and service-friendly motor control with a range of setting options
- numerous connection possibilities for accessory, e. g. light barriers (photo cell), induction loops, ...
- stylish LED lighting offers optimum safety, separately replaceable if required
- integrated warning light with a clearly visible signal effect

## TECHNICAL DATA

Temperature range	-20°C to +60°C
Opening width of LED boom	max. 4,55 m
Weight	approx. 40 kg
Power supply	AC 230 V, 50/60 Hz
Motor power	80 W, DC 24 V
Permitted cycles per day	max. 350
IP code	IP44



1) also available in FM 434.42 MHz. 2) recommended from a barrier arm length > 3 m.

# ASB-6010

The steel barrier with 6 m arm



8

- simple and fast mounting due to the "Plug & Go" principle: install, plug-in, ready!
- barrier arm can be easily shortened on site
- easily operated via integrated SOMMER radio receiver (FM 868.8 MHz)<sup>1)</sup>
- the automatic obstruction detection ensures optimum protection: when it contacts an obstacle the barrier opens automatically and ensures that no vehicle is clamped
- the operating force of our barriers is certified according to EN 12445 and EN 12453
- the barrier can be manually opened and closed in any position by means of the emergency crank (e.g. in the event of a power failure)
- pluggable and service-friendly motor control with a range of setting options
- numerous connection possibilities for accessory, e.g. light barriers (photo cell), induction loops, ...
- also available at SOMMER are support posts and torque support arms<sup>2)</sup>

## TECHNICAL DATA

Temperature range	-20°C to +60°C
Opening width	max. 5,55 m
Weight	approx. 60 kg
Power supply	AC 230 V, 50/60 Hz
Motor power	80 W, DC 24 V
Permitted cycles per day	max. 350
IP code	IP44



<sup>1)</sup> also available in FM 434.42 MHz. <sup>2)</sup> The floating support is only certified for the ASB-6010 and ASB-6010A models and a boom length of up to 5m. Please only use support posts or floating supports.



# ASB-6010A

The aluminium barrier with 6 m arm



- simple and fast mounting due to the "Plug & Go" principle: install, plug-in, ready!
- barrier arm can be easily shortened on site
- easily operated via integrated SOMMER radio receiver (FM 868.8 MHz)<sup>1)</sup>
- the automatic obstruction detection ensures optimum protection: when it contacts an obstacle the barrier opens automatically and ensures that no vehicle is clamped
- the operating force of our barriers is certified according to EN 12445 and EN 12453
- the barrier can be manually opened and closed in any position by means of the emergency crank (e.g. in the event of a power failure)
- pluggable and service-friendly motor control with a range of setting options
- numerous connection possibilities for accessory, e.g. light barriers (photo cell), induction loops, ...
- also available at SOMMER are support posts and torque support arms<sup>2)</sup>
- integrated warning light with a clearly visible signal effect

## TECHNICAL DATA

Temperature range	-20°C bis +60°C
Opening width	max. 5,55 m
Weight	approx. 40 kg
Power supply	AC 230 V, 50/60 Hz
Motor power	80 W, DC 24 V
Permitted cycles per day	max. 350
IP code	IP44



<sup>1)</sup> also available in FM 434.42 MHz. <sup>2)</sup> The floating support is only certified for the ASB-6010 and ASB-6010A models and a boom length of up to 5m. Please only use support posts or floating supports.

# THE MATCHING ACCESSORIES FOR THE OPTIMAL BARRIER SYSTEM

## SAFETY

### 1 Main switch

The connectible main switch de-energises the barrier at all poles (according to EN 12453).

### 2 Light barrier

The light barrier detects objects and sends a signal to the control unit upon detection. The barrier closing process can be prevented, for example, if a vehicle is in the access area.

### 3 Rod antenna

An outdoor antennae can ensure even greater radio range in difficult environmental conditions.

### 4 5 Torque support arm<sup>1) 2)</sup> and support post<sup>2)</sup>

At a boom length over 3 metres, the use of a floating support or a support post is recommended for additional stability.

### 6 Induction loop detector

For the inductive detection of vehicles. Area for use: Barriers, parking and traffic technology, gates, doors.

### 7 Warning light

The users of the barrier are warned of an opening or closing barrier by the warning light.

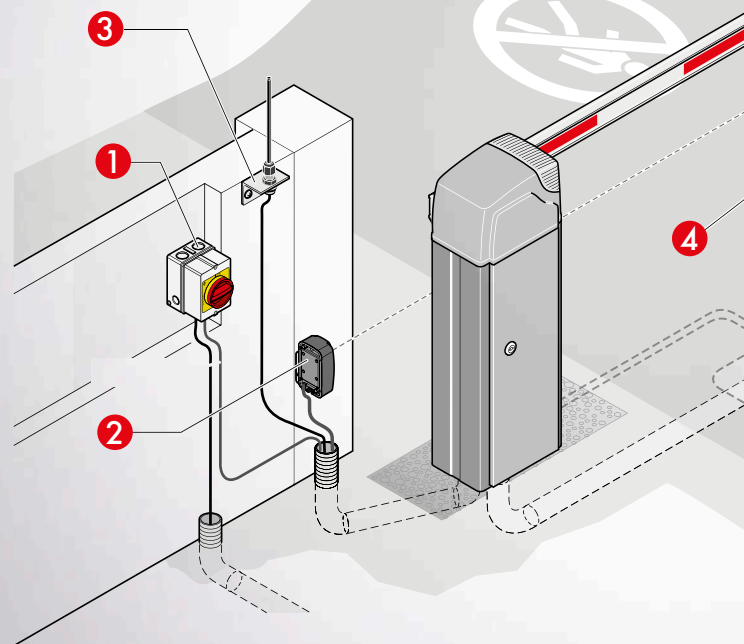

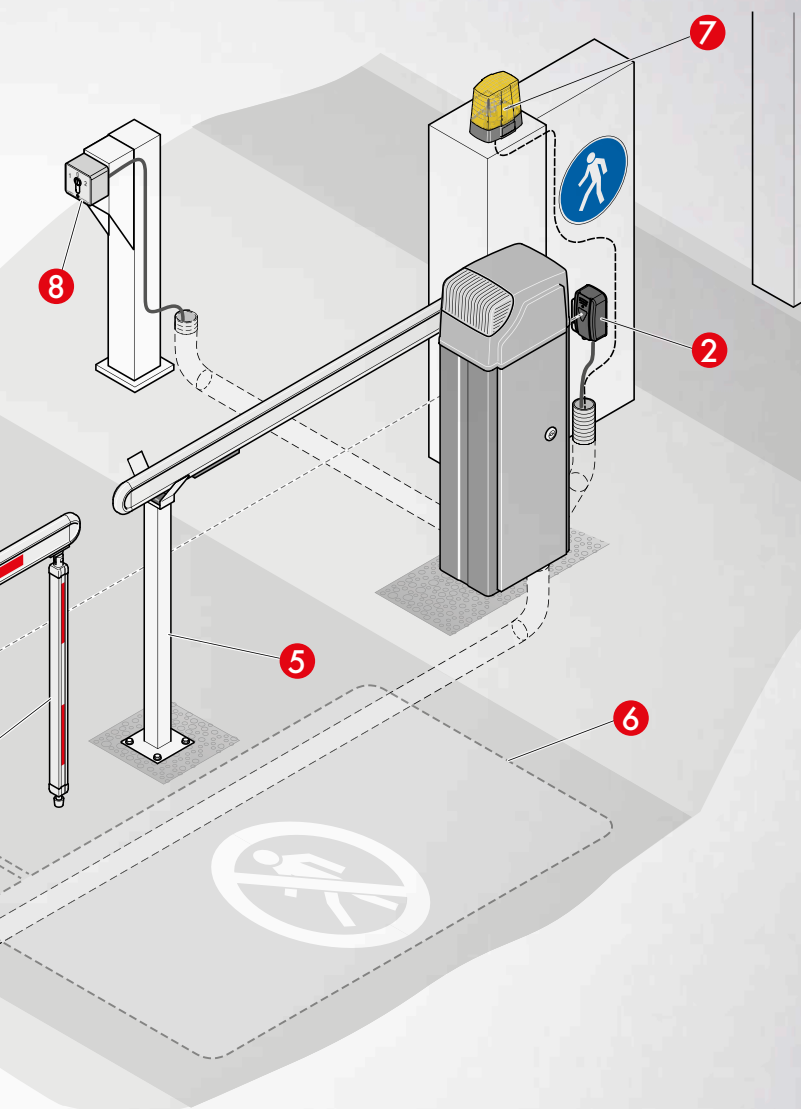

## CONVENIENCE

### 8 Key switch/Key switch post

The barrier opens or closes when the key switch is activated. We offer a wide variety of models for wall or recessed installation, either with or without a profile cylinder.

### Radar motion detector

Used as an impulse transmitter for barrier and door systems and enables vehicle or person detection including cross traffic suppression.

### "LED barrier arm" conversion set

- Only for converting/retrofitting the "ASB-6010A" barrier
- Scope of supply: 5 m boom with LED lighting, boom cover and installation materials.

### Transmitter

Whether a transmitter or Telecody, At SOMMER you'll find the right product tailored to suit your needs, and you can operate your barrier system conveniently via radio signal.

# IT'S IN YOUR HANDS

YOU WILL BE AMAZED BY WHAT CAN BE OPERATED BY RADIO TECHNOLOGY AND HOW MUCH CONVENIENCE YOU'LL GAIN

Our radio solutions allow you to have individual freedom over your own home automation systems in the garden or in the garage.

At SOMMER, security and convenience go hand in hand. Only when you have that peace of mind can you fully reap the benefits of our limitless radio options.

## Radio power sockets

Allowing you to activate or de-activate the supply voltage of an automated application, such as a lamp. This then enables you to switch on the lamp by simply pressing a button on your transmitter and switch it off again by pressing another button.

12



#7017V000

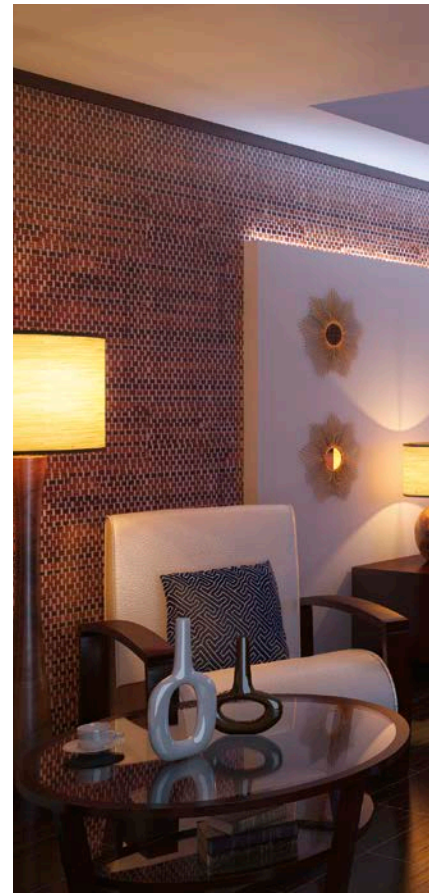

## Radio wall switches

Your home automation applications, such as operators, blinds, roller shutters or awnings, can be operated conveniently at the push of a button using the indoor radio switches.



#4762V001



#4762V000



**Transmitters**

Whether a transmitter or Telecody, at SOMMER you'll find the right product tailored to suit your needs.



# 4035V002  
Ruby



# 4019V000  
Pearl Vibe



# 4071V000  
Telecody



**Access control systems**

With the biometric recognition feature of SOMMER fingerprint systems, you can open garage and yard gates with one gentle finger motion. The radio code switches allow you to open your garage doors and yard gates with an individually programmable digit code.



Slide-open housing

# 5052V000  
ENTRAsys GD



Slide-open housing

# 4090V000  
ENTRApin

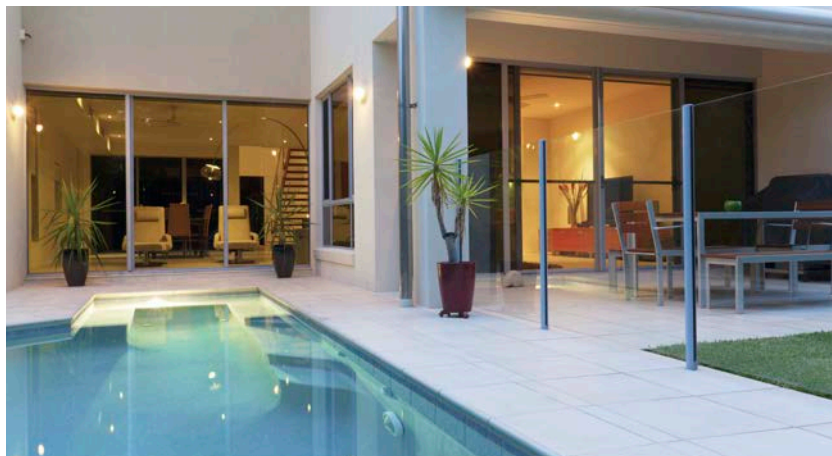

# SECURITY ASSURED WITH THE PERFECT SOLUTION



14

- GARAGE DOOR OPERATORS
- UNDERGROUND PARKING  
GARAGE DOOR OPERATORS
- SWING AND SLIDING GATE  
OPERATORS
- RADIO TECHNOLOGY
- HOME AUTOMATION
- ACCESS CONTROL SYSTEMS





- ROLLER SHUTTER OPERATORS
- AWNING DRIVES
- ROLLER DOOR CONTROL UNITS
- INDUSTRIAL DOOR OPERATORS
- PARKING AND BLOCKING SYSTEMS
- ACCESSORIES

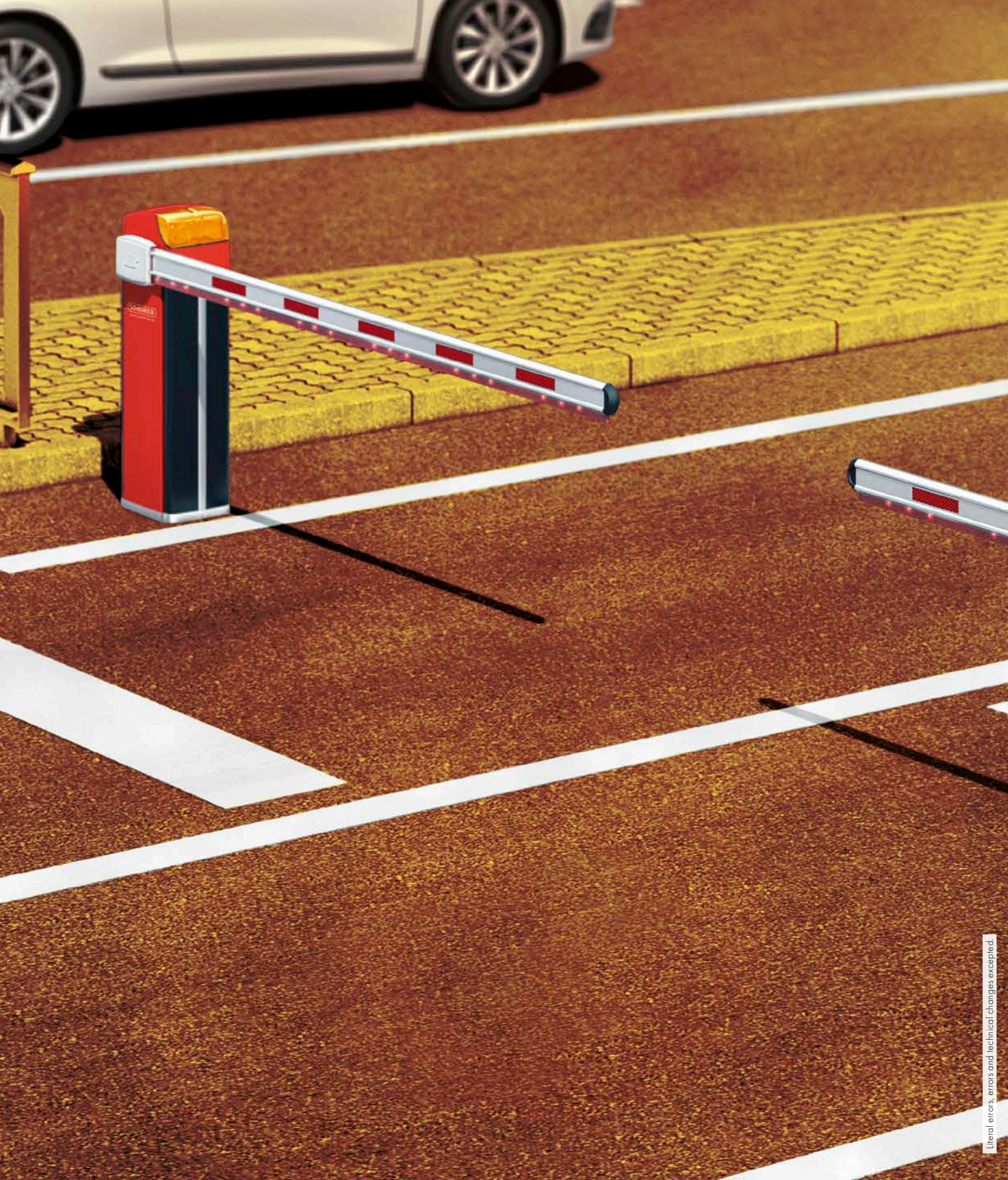

Literal errors, errors and technical changes excepted.



**SOMMER ANTRIEBS- UND FUNKTECHNIK GMBH**  
HANS-BÖCKLER-STR. 21-27 | D-73230 KIRCHHEIM/TECK  
PHONE +49 (0)7021/8001-0 | FAX +49 (0)7021/8001-100  
INFO@SOMMER.EU | WWW.SOMMER.EU



SOMMERGMBH



SOMMER\_GMBH

GB #46-5056V001-03/15